

MODEL DDT DIRECT DRIVEN TUBEAXIAL DUCT FANS



6393 Powers Avenue
Jacksonville, Florida 32217-2298
P: 800.961.7370 / F: 800.961.7379
www.solerpalau-usa.com

STANDARD FEATURES

- Housing - Heavy-gauge rolled steel, continuously welded.
- Propellers available in steel or aluminum.
- Heavy steel hub with taper-loc bushing.
- Motor located in airstream.
- Prepunched welded flange rings.

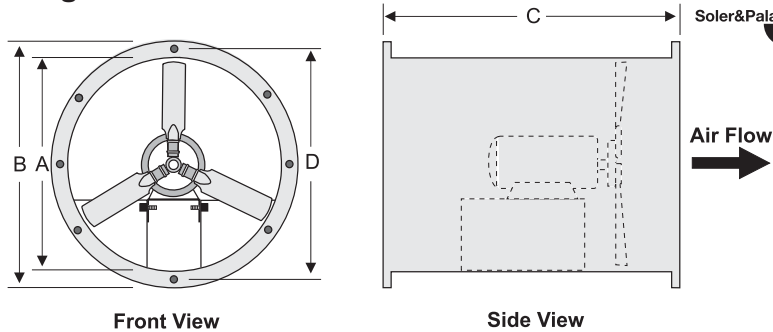

Model No.	Housings			Flange Hole Center D	Holes		Max Motor Frame	Steel Housing Gauges	Avg. Ship Wt. (Lbs)
	I.D. A	O.D. B	Length C		Dia.	#			
12	13 1/32	16 3/16	15	15	1/2	8	56	14	60
16	17 1/32	20 3/16	19	19	1/2	8	56	14	65
18	19 1/32	22 3/16	19	20 3/4	1/2	8	143T	14	75
21	22 1/32	25 3/16	19	23 3/4	1/2	8	145T	14	90
24	25 1/8	29 1/8	30	27 1/8	1/2	8	213T	12	130
30	31 1/8	35 1/8	30	33 1/8	1/2	8	215T	12	195
36	37 1/8	41 1/8	30	39 5/8	1/2	8	215T	12	250
42	43 1/8	47 1/8	32	45 1/8	1/2	8	256T	12	400
48	49 1/8	53 1/8	32	51 1/5	1/2	8	256T	10	510

NOTE: All dimensions shown are in inches.

FAN SPECIFICATIONS									MOTOR SPECIFICATIONS								
Line	Qty.	Model No.	Tag	CFM	SP	Fan RPM	BHP	Sones	HP	Volts	Phase	Hertz	Encl				
1																	
2																	
3																	
4																	
5																	
ACCESSORY ITEMS				1	2	3	4	5	ACCESSORY ITEMS				1	2	3	4	5
				<input type="checkbox"/>	<input type="checkbox"/>	<input type="checkbox"/>	<input type="checkbox"/>	<input type="checkbox"/>					<input type="checkbox"/>	<input type="checkbox"/>	<input type="checkbox"/>	<input type="checkbox"/>	<input type="checkbox"/>
				<input type="checkbox"/>	<input type="checkbox"/>	<input type="checkbox"/>	<input type="checkbox"/>	<input type="checkbox"/>					<input type="checkbox"/>	<input type="checkbox"/>	<input type="checkbox"/>	<input type="checkbox"/>	<input type="checkbox"/>
				<input type="checkbox"/>	<input type="checkbox"/>	<input type="checkbox"/>	<input type="checkbox"/>	<input type="checkbox"/>					<input type="checkbox"/>	<input type="checkbox"/>	<input type="checkbox"/>	<input type="checkbox"/>	<input type="checkbox"/>
				<input type="checkbox"/>	<input type="checkbox"/>	<input type="checkbox"/>	<input type="checkbox"/>	<input type="checkbox"/>					<input type="checkbox"/>	<input type="checkbox"/>	<input type="checkbox"/>	<input type="checkbox"/>	<input type="checkbox"/>
				<input type="checkbox"/>	<input type="checkbox"/>	<input type="checkbox"/>	<input type="checkbox"/>	<input type="checkbox"/>					<input type="checkbox"/>	<input type="checkbox"/>	<input type="checkbox"/>	<input type="checkbox"/>	<input type="checkbox"/>

Project: _____ Submitted: _____
 Customer: _____ Approved: _____
 Location: _____