

MODEL CSF FILTERED SUPPLY FAN



6393 Powers Avenue
Jacksonville, Florida 32217-2298
P: 800.961.7370 / F: 800.961.7379
www.solerpalau-usa.com

STANDARD FEATURES

- AMCA Air Licensed.
- cULus Listed - Standard 705 (optional).
- Disconnect standard (Except two speed and explosion proof).
- Heavy-gauge galvanized construction.
- Statically and dynamically balanced forward curved wheel.
- Variable pitch drives standard.
- Drives sized for a minimum of 150% of drive horsepower.
- 5-year fan, and 1-year motor warranty.
- Heavy-duty L50 200,000 hour rated pillow block bearings.
- Low profile.
- Integral deep spun inlet.

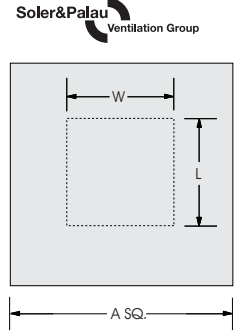
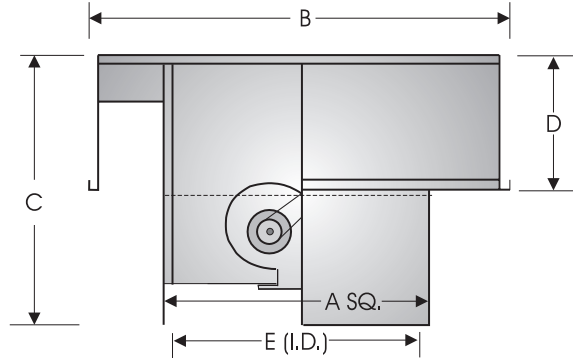

Discharge Opening

Size	Housing O.D. A	Overall Width B	Overall Height C	D	E (Curb Cap I.D.)	W	L	Filters (Qty)
9	24-1/2	33-1/2	26-1/2	10-1/2	24 x 24	12	10-1/2	16 x 20 (4)
10	28-1/2	38-1/2	28-1/4	12-1/2	28 x 28	13-1/4	11-5/8	16 x 25 (4)
12	28-1/2	38-1/2	28-1/4	12-1/2	28 x 28	15-7/8	13-5/8	16 x 25 (4)
15	32-1/2	46-1/2	26	16	32 x 32	18-3/4	16	16 x 25 (4)
18	36-1/2	46-1/2	30	20	36 x 36	22-1/4	19-1/8	20 x 25 (4)
20	51-1/4	70	43	21	51 x 51	23-3/16	25	20 x 25 (8)

Roof Curb Dimensional Data

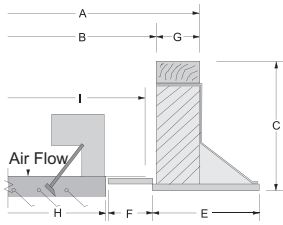

Size	Prefab Curb O.D. A	Prefab Curb I.D. B	Curb Height C	E	F	G	H	I
9	22-3/4	19-1/2	8	7	1-1/2	1-1/2	16	19
10	26-1/2	23-1/2	8	7	1-1/2	1-1/2	20	23
12	26-1/2	23-1/2	8	7	1-1/2	1-1/2	20	23
15	30-1/2	27-1/2	8	7	1-1/2	1-1/2	24	27
18	34-5/8	31-3/8	8	7	1-1/2	1-1/2	27	30
20	49	46	8	7	1-1/2	1-1/2	42	45

Duct Adaptor Dimensional Data

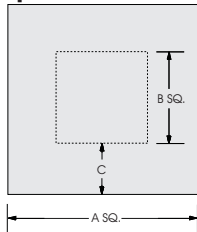

Size	A Sq.	B Sq.	C (Out to In)
9	18-1/2	14-1/2	2
10	22-1/2	18-1/2	2
12	22-1/2	18-1/2	2
15	26-1/2	20-1/2	3
18	30-1/2	24-1/2	3
20	45	30	7-1/2



FAN SPECIFICATIONS									MOTOR SPECIFICATIONS				
Line	Qty.	Model No.	Tag	CFM	SP	Fan RPM	BHP	Sones	HP	Volts	Phase	Hertz	Encl
1													
2													
3													

ACCESSORY ITEMS					ACCESSORY ITEMS				
1	2	3	4	5	1	2	3	4	5

MODEL CSF FILTERED SUPPLY FAN SIDE DISCHARGE



6393 Powers Avenue
Jacksonville, Florida 32217-2298
P: 800.961.7370 / F: 800.961.7379
www.solerpalau-usa.com



STANDARD FEATURES

- AMCA Air Licensed.
- cULus Listed - Standard 705 (optional).
- Disconnect standard (Except two speed and explosion proof).
- Heavy-gauge galvanized construction.
- Statically and dynamically balanced forward curved wheel.
- Variable pitch drives standard.
- Drives sized for a minimum of 150% of drive horsepower.
- 5-year fan, and 1-year motor warranty.
- Heavy-duty L50 200,000 hour rated pillow block bearings.
- Low profile.
- Integral deep spun inlet.

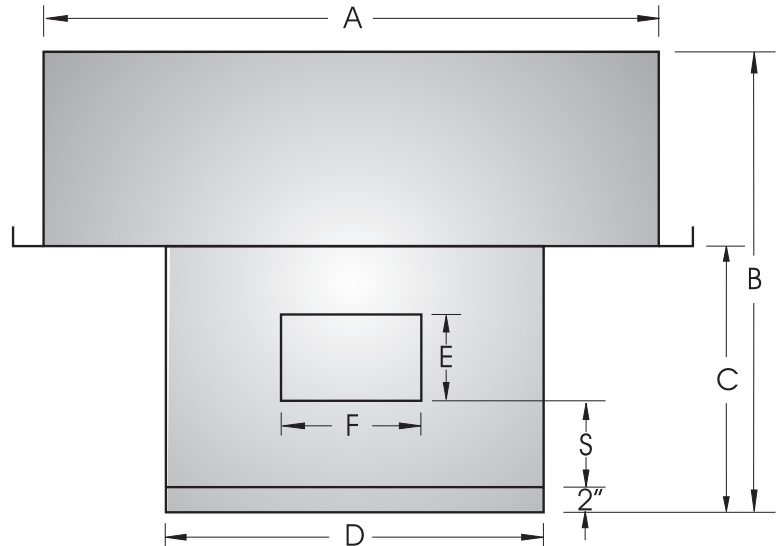

Size	Housing O.D. A Sq.	Overall Height B	Stack Height C	Curb Cap (I.D.) D Sq.	Discharge Opening E x F	S	Avg. Ship Wt.
CSF-10SD	38-1/2	40-1/4	28	28	11-5/8 x 13-1/4	7-3/4	290
CSF-12SD	38-1/2	40-1/4	28	28	13-5/8 x 15-7/8	9-3/8	340
CSF-15SD	46-1/2	44	28	32	16-1/8 x 18-3/4	10-3/8	380
CSF-18SD	46-1/4	56-3/8	36	36	19-1/6 x 22-1/4	13	540
CSF20SD	70	65	45	51	23-1/8 x 25	13-1/8	890

FAN SPECIFICATIONS									MOTOR SPECIFICATIONS				
Line	Qty.	Model No.	Tag	CFM	SP	Fan RPM	BHP	Sones	HP	Volts	Phase	Hertz	Encl
1													
2													
3													
4													
5													

ACCESSORY ITEMS					ACCESSORY ITEMS				
1	2	3	4	5	1	2	3	4	5

MODEL LSF FILTERED SUPPLY FAN with LOUVERED HOUSING



6393 Powers Avenue
Jacksonville, Florida 32217-2298
P: 800.961.7370 / F: 800.961.7379
www.solerpalau-usa.com

STANDARD FEATURES

- AMCA Air Licensed.
- cULus Listed - Standard 705 (Optional).
- Disconnect standard (Except two speed and explosion proof).
- Heavy-gauge galvanized construction (Louvered Aluminum).
- Statically and dynamically balanced forward curved wheel.
- Variable pitch drives standard.
- Drives sized for a minimum of 150% of drive horsepower.
- 5-year fan, and 1-year motor warranty.
- Heavy-duty L50 200,000 hour rated pillow block bearings.
- Low profile.
- Integral deep spun inlet.

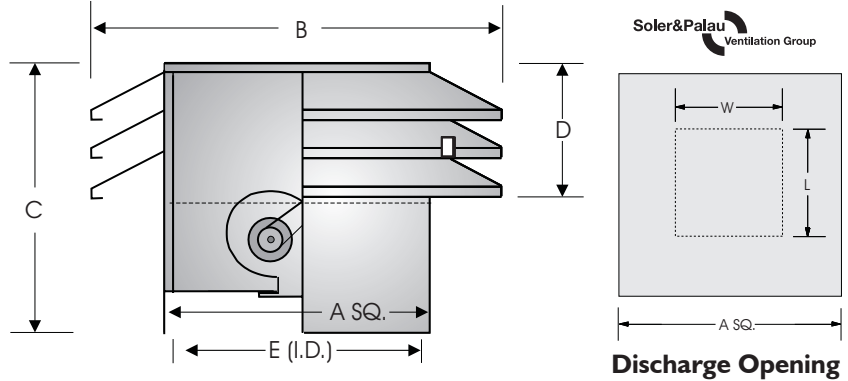

Size	Housing O.D. A	Overall Width B	Overall Height C	D	No. Tiers	E (Curb Cap I.D.)	W	L	Filters (Qty)
9	24-1/2	32	28-1/2	16	3	24 x 24	12	10-1/2	16 x 20 (4)
10	28-1/2	36	28-1/2	16	3	28 x 28	13-1/4	11-5/8	16 x 25 (4)
12	28-1/2	36	28-1/2	16	3	28 x 28	15-7/8	13-5/8	16 x 25 (4)
15	32-1/2	40	30	21-1/2	4	32 x 32	18-3/4	16-1/4	21-1/2 x 28 (4)
18	36-1/2	44-1/4	35	26-1/2	5	36 x 36	22-1/4	19	24 x 30 (4)
20	51-1/4	59	47	26-1/2	5	51 x 51	23-3/16	25	25-1/2 x 45-1/2 (8)

Roof Curb Dimensional Data

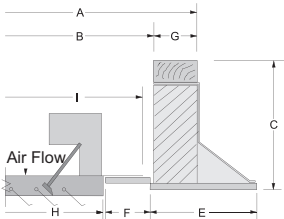

Size	Prefab Curb O.D. A	Prefab Curb I.D. B	Curb Height C	E	F	G	H	I
9	22-3/4	19-1/2	8	7	1-1/2	1-1/2	16	19
10	26-1/2	23-1/2	8	7	1-1/2	1-1/2	20	23
12	26-1/2	23-1/2	8	7	1-1/2	1-1/2	20	23
15	30-1/2	27-1/2	8	7	1-1/2	1-1/2	24	27
18	34-5/8	31-3/8	8	7	1-1/2	1-1/2	27	30
20	49	46	8	7	1-1/2	1-1/2	42	45

Duct Adaptor Dimensional Data

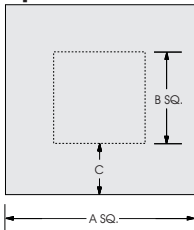

Size	A Sq.	B Sq.	C (Out to In)
9	18-1/2	14-1/2	2
10	22-1/2	18-1/2	2
12	22-1/2	18-1/2	2
15	26-1/2	20-1/2	3
18	30-1/2	24-1/2	3
20	45	30	7-1/2



FAN SPECIFICATIONS										MOTOR SPECIFICATIONS				
Line	Qty.	Model No.	Tag	CFM	SP	Fan RPM	BHP	Sones	HP	Volts	Phase	Hertz	Encl	
1														
2														
3														

ACCESSORY ITEMS					ACCESSORY ITEMS				
1	2	3	4	5	1	2	3	4	5