



**STANDARD CONSTRUCTION**

**DEPTH:** 4 ¼ inches (108 mm)

**FRAME:** Roll formed 20 GA. galvanized steel with hemmed edge

**BLADE:** Roll formed 22 GA. galvanized steel. Interlocking curtain type blade.

**FUSIBLE LINK:** 165°F (73.9°C)

**OPTIONAL CONSTRUCTION**

- Factory supplied Sleeve – 22, 20, 18 or 16 GA. \*Sleeve length required
- Round Transitions
- Access Door factory mounted in a common sleeve to ensure compliance with UL installation requirements
- Fusible Link 212°F (100°C)
- 1 ½" x 1 ½" mounting angles

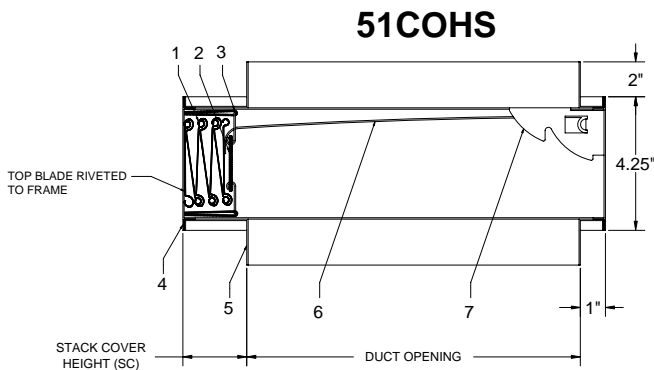
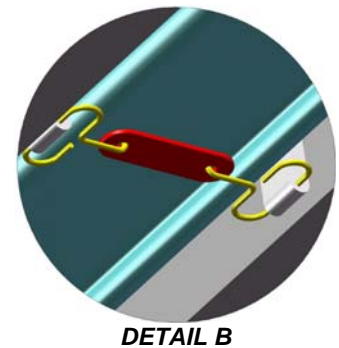
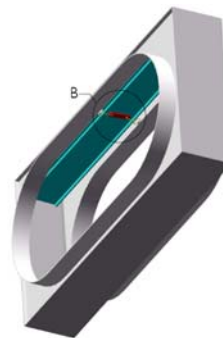
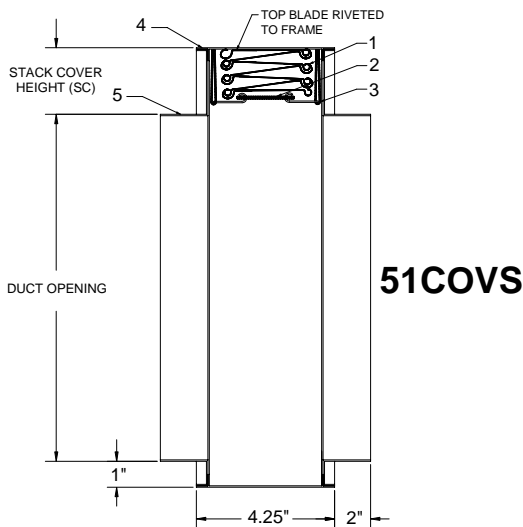

**MANUFACTURERS RECOMMENDATIONS:**

All moving parts of the damper must be inspected and cycled at intervals not greater than every 6 months and in accordance with the latest edition of NFPA 90A, 92A, local codes. In addition, fuse links shall be removed and inspected for corrosion.

**NOTES:**

Dampers are furnished a minimum of ¼" (6.4 mm) smaller than the given duct dimensions. For complete instructions refer to Alumavent installation instructions for curtain type fire dampers.

"These dampers are UL/ULC Approved for use in static systems where the fan shuts down in the event of fire".

FIRE DAMPER COMPONENTS	
1. Blade	5. Collar
2. Fusible Link Assembly	6. Lock Ramp
3. Link Strap	7. Constant Force Spring
4. Frame	



Underwriters Laboratories (UL555) classified fire dampers. Fire resistance rated 1 ½ hour for use in UL classified building materials 2 hours or less.

B	H
4	6
5	7
6	8
7	9
8	11
9	12
10	13
11	14
12	15
13	16
14	17
15	18
16	19
17	21
18	22
19	23
20	24
21	25
22	26
23	27
24	28
25	29
26	30
27	32
28	33
29	34
30	35
31	36
32	37
33	38
34	39
35	40
36	42
37	43
38	44
39	45
40	46
41	47
42	48
43	49
44	50
45	52
46	53
47	54
48	55
49	56
50	57
51	58
52	59
53	60

\* W = A + 2"

\*UNITS: INCHES (mm)

## VERTICAL

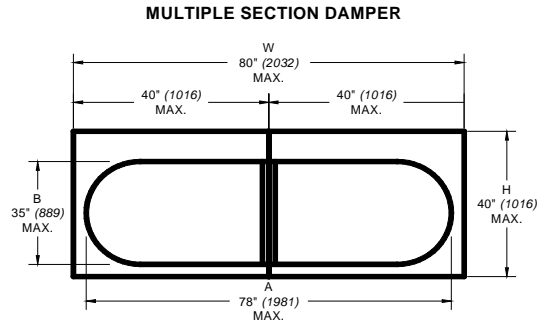
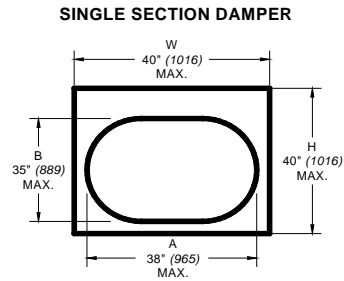
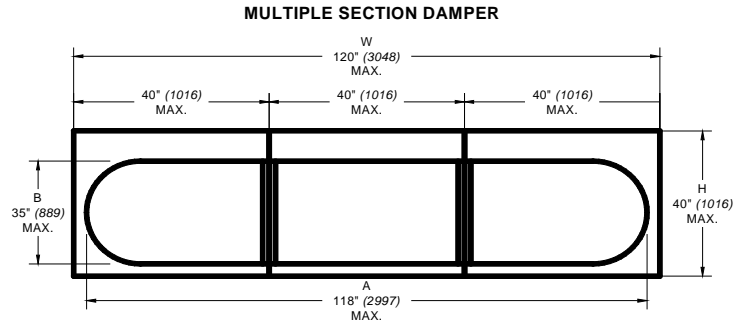
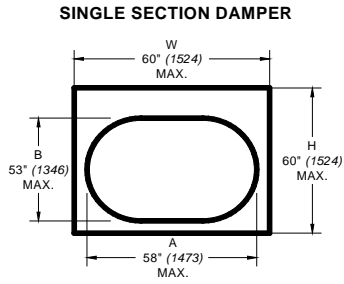

## HORIZONTAL

REF. #	QTY.	DUCT WIDTH A [in]	DUCT HEIGHT B [in]	MOUNT (V/H)	ACCESSORIES

\*DAMPER WILL BE MANUFACTURED A MINIMUM OF 1/4" (6.4 mm) SMALLER THAN GIVEN DUCT DIMENSIONS.

<b>PROJECT NAME:</b>	<input type="text"/>	<b>ENGINEER:</b>	<input type="text"/>
<b>CONTRACTOR:</b>	<input type="text"/>	<b>SUBMITTAL DATE:</b>	<input type="text"/>